

# **OCS-XZ Series**

## **Electronic Crane Scale**

# **User's Guide**

## **Table of Contents**

1. Brief Introduction
2. Features & Specifications
3. Functions of Key Pad & Indicators
4. Basic Operations
  - Power ON
  - Initial on Zeroing
  - Manual Addition
  - Display of Total Weight
  - Set Parameters
  - Initial on Zero Range Setup
  - Clear
  - Weighing
  - Power OFF
5. Battery Charging
6. scale care
7. Calibration
8. Dimensioned Drawing of Scale
9. Instruction of Remote Control

## 1. Overview

OCS-XZ series crane scale is a high-tech scale. The digital crane scale employs both the advanced hardware and sophisticated software. It uses AT-89 series single-chip micro-processor and highly precision A/D converter. In addition, the crane scale is equipped with specially designed compensating circuitry for rocking loads. With its quick stabilization and strong interference-rejection, it can be widely used in weighing applications in commerce, industrial and mining industries, and warehousing wharf, etc.

## 2. Features & Specifications

|                                 |   |
|---------------------------------|---|
| Accuracy Class                  | National Standard –Accuracy Class III                                 |
| Initial on Zero Range           | Selectable 0%、 5%、 10%、 20%、 50%、 100% F.S                            |
| Time to Stable Static Reading   | ≤10 seconds   |
| Maximum Safe Load               | 150% F.S.   |
| Display Screen                  | Super bright 1.2" 5-digit LED display                                 |
| Operating Temperature           | -10 °C ~ +40°C  |
| Operating Humidity              | ≤85%RH  |
| LOB Indicator                   | When the power is low, the indicator will be on                       |
| Auto-OFF                        | The scale will shut off automatically once the power is severely low. |
| Recharging Protective Circuitry | To prolong the performing life of the battery                         |
| Cast Aluminum Housing           | Rust protection, antistatic & light weight                            |

| Model     | Weigh Capacity (Kg) | Division | Resolutions |
|-----------|---------------------|----------|-------------|
| OCS-XZ-06 | 600                 | 0.2      | 3000        |
| OCS-XZ-1  | 1000                | 0.5      | 2000        |
| OCS-XZ-2  | 2000                | 1        | 2000        |
| OCS-XZ-3  | 3000                | 1        | 3000        |
| OCS-XZ-5  | 5000                | 2        | 2500        |
| OCS-XZ-10 | 10000               | 5        | 2000        |

## 3. Functions of Key Pad & Indicators

Presented below is the scale panel:

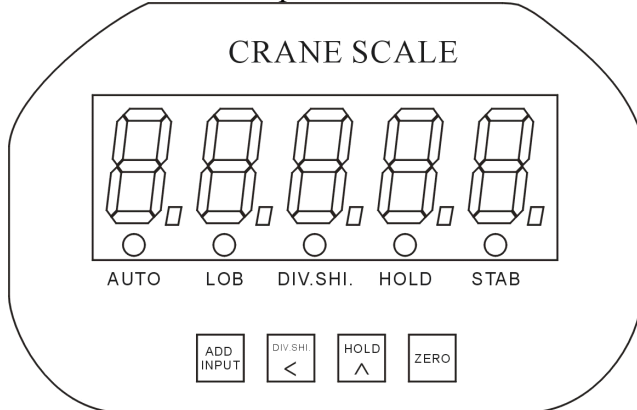

As presented on the panel, [ADD/INPUT], [DIV.SHI/<], [HOLD/^], [ZERO] are operating keys, of whose functions are in the following:

- a) [ADD/INPUT] – Use this key to add the load weight. It is only usable when the scale is in manual mode of operation.
- b) [DIV.SHI/<] – Use this key to select the resolution. Except the resolution listed in the table above, we can select the required resolution smaller than the listed ones. If the set value is the minimum resolution of the scale, the [DIV.SHI] indicator will be ON.
- c) [HOLD/^] – Press this key to keep the current displaying weight and the [HOLD] indicator will be on. Press the key again to turn off temporarily holding function.
- d) [ZERO] – Press this key to zero the current displaying value.

On the panel, **AUTO**, **LOB**, **DIV.SHI**, **HOLD** and **STAB** are indicators

- e) **Auto** – This indicator is on when the scale is in Auto-Add mode.
- f) **LOB** - This indicator is ON when the voltage is less than 6V.
- g) **DIV.SHI** - When it is ON, it indicates that the current division value is at or less than the minimum resolution of the scale.
- h) **HOLD** - When it is ON, it indicates that the scale is in temporarily holding mode.
- i) **STAB** – When it is ON, it indicates that the acquired weight data is stable.

## 4. Basic Operations

### 4.1 Power On

Turn on the power switch at the back of scale to the ON position. The scale will display the version number and then the maximum weight capacity individually for one second. Then the nixie light will display “99999”, “88888” ..... “00000” in turn. Then scale will undergo self-check of reset sequence and indicators with LED indicators on and off alternatively and finally come into weighing mode.

### 4.2 Initial on zeroing

After power on, the scale enters into weighing mode and then displays “0”kg. If it is not “0”kg, it's normally caused by overloading the permitted value of the initial on zero range. In this

case, please switch off the scale and re-start it and choose the desired parameter. (Please see initial on zero Range below.)

### 4.3 Manual Addition

When the displaying value is over zero, with weight on the scale, pressing [ADD/INPUT] key, the current weighing value will be added to the total weight if with valid parameter. (Please see 4.5 Set Parameters.) The scale will show "bXXXX" for about one second. Here, "b" means the total number of loads and "XXXX" indicates the total number of adding.

**Note:** No matter manual add or auto-add, please zero the displaying value before another manual adding. Here, the zeroing range includes 20 division value of the capacity. When the number of adding reaches 9999, it will display FULL which indicates full memory. In this case, please clear the memory according to "4.7 Clear" in the following.

### 4.4 Display of Total Weight

When the displaying value is within the zeroing range, press key [ADD/INPUT] to see the total number of adding and the total weight of loads. It will firstly display the total number of loads. For example, the scale shows "b0327" indicating 327 loads weighed so far. Press [ADD/INPUT] again, it will display the four left-hand number of the added value. For instance, "H 108" indicates the left-hand number of the total weight is "108". Press [ADD/INPUT] for the third times, it will show the four right-hand number of the total weight. For your reference, "L 2896" indicates the right-hand number of the total weight is "2896". Accordingly, the total weight of the loads is "1082896 kg".

### 4.5 Set Parameters

Press key [Zero] during self-checking and it will display "PXYZ". Here, "XYZ" is decimal number which can be revised by pressing key [HOLD/^] or [DIV.SHI/<] (Please see 7. Calibration ). The valid range of the three numbers is between 0 and 255. If inputting a number from 256 to 999, the data recognized by the scale is equal to the remainder after division by 256.

"XYZ" can be represented by 8 binary digits described as follows:

D0: Selection between Manual Adding and Auto-Adding, digit 1 indicates Auto-Adding.

D1: Non-Beeper and Beeper when the weighing value becoming stable, digit 1 means you selecting beeper.

D2: Selecting Close or Activate Zero point drift, digit 1 is to activate the Zero point drift.

D3.D4: To switch off the scale. When D4=0, the scale will keep displaying no matter what D3 is. When D4=1, D3=1 the scale will keep working for 30 minutes with stable weighing value displayed and then power-off automatically. When D3=0, the displaying window will go into sleeping mode with stable weighing value for 30 minutes. It will be activated when the displaying value is unstable or press the key [DIV.SHI/<].

D5: Digit 1 means that pressing [ADD/INPUT] with stable displaying value is valid when manual adding selected. Digit 0 means [ADD/INPUT] is valid with unstable displaying value.

D6-D7: Any digit is valid but 0 is recommended.

D0-D7 mentioned above respectively represents the 8 binary digits, with valid value 0 or 1.

$XYZ = 128 * D7 + 64 * D6 + 32 * D5 + 16 * D4 + 8 * D3 + 4 * D2 + 2 * D1 + D0$ .

For example, XYZ=62 indicates: D7=0, D6=0, D5=1, D4=1, D3=1, D2=1, D1=1, D0=0, this is the default values set during manufacturing in the factory.

When displaying "PAXYZ", if press [ADD/INPUT], the selected data will be saved (The data will still be saved even the scale is powered off.) The scale will come into weighing mode after self-checking. Press [ZERO] to enter into the state of setting zeroing range.

#### **4.6 Initial on zero range Setup**

During the process of self-check at Power ON, press [ZERO] to show "PAXYZ". Press [ZERO] again to show " O UUU". Here, "O" indicates the function of initial on zero range. If "UUU" equals to 20, it means the present zeroing range is 20% which is default values set during manufacturing in the factory. Use key [HOLD/^] to change the initial on zero range. After selection, press [ADD/INPUT] to save the selected parameters of "PAXYZ" and the zeroing range and confirm the operation. The scale will go into weighing mode after self-checking. If you press [ZERO], it will go to clearing mode.

#### **4.7 Clear**

During the self-checking at Power on, press [ZERO] and it will display "PAXYZ". Press [ZERO] twice after "PAXYZ", it will display "CLEAR". Press [ADD/INPUT] to save the parameters and the zeroing range. Meanwhile, the total number of loads and the total weight will be cleared during this operation. The scale will change into weighing mode after self-check. If you press [ZERO] instead of [ADD/INPUT], the set parameters in the previous operation will not be kept and used. The scale then will go into mode of limiting weight/ calibration.

#### **4.8 Weighing**

During the weighing process, the weight is ready to be recorded when the stable weight result is shown and the STAB indicator is on. If there is tare involved, such as rope or container, weigh them first. Press [ZERO] to apply tare. The display should now be "0.0kg", the net weight. With no change to the tare, the loads weighed afterwards will be their net weights until the change of tare value or the scale is turned off.

#### **4.9 Power Off**

After the weighing operation, turn off the scale by using the power switch on the back of the scale.

### **5. Battery Charging**

- 5.1 It adopts maintenance-free rechargeable battery (6V/4Ah) and smart charger (DC6V/1Ah).
- 5.2 Then LOB indicator will be on if there is low power. The battery needs to be charged now. The scale, however, can continue to operate for about 5hours without charging.
- 5.3 After the LOB indicator is ON for several hours without charging or there is no more power in the battery, the scale will be powered off automatically. It will take about 5 hours to fully charge the battery.
- 5.4 After battery charging, if there is no display, it indicates that either there is difficulty in battery charging or a damaged battery. Please contact supplier for repair or replacement.
- 5.5 To prolong the battery life, we suggest you charge the battery no less than once per week. If the scale needs not to be charged for long time, you should charge it no less than once per week. To avoid any damage to the battery, please charge it correctly. Additionally, we suggest you switch off the scale to short the charging time.

## 6. Scale Care

- 6.1 Do not overload the scale to prevent the damage to the force transducer inside the scale. It will alarm you with buzzer and display “OVER1” if overloaded.
- 6.2 If display “Err01” after power on the scale, indicators that it will influence the accuracy or the important parameters lost.
- 6.3 Please check the scale frequently to insure the safe use. The basic checking list is:
- 6.3.1 Whether the screw has come loose
  - 6.3.2 Whether the hook or shackle or any other component is cracked or distorted
  - 6.3.3 If the mechanical components showing sign of metal fatigue or defects
  - 6.3.4 Whether the pin is off or the components are lost.
- If there is any sign of the mentioned condition, please send the scale or components back to the manufacturer for repair or exchange before using the scale again.
- 6.4 Avoid any impact to the display panel.
- 6.5 Do not use the scale under wet or heavily polluted conditions.

## 7. Calibration

| Steps | Operation   | Display | Remarks  |
|-------|---|---------|--|
| 1     | During self-check, press [ZERO]. After “PAXYZ”, press [ZERO] three times.                                 | 00000   | 1 <sup>st</sup> step of calibration. Password is required.                                     |
| 2     | Press [HOLD/^] to select the desired number, press [DIV.SHI/<] to shift digit                             | *****   | ***** is the password  |
| 3     | After entering password, press [ADD/INPUT]  | SPEN    | There should be no load on the scale   |
| 4     | Press [ADD/INPUT]   | 4112    | 4112 is the encode at zeroing loading  |
| 5     | press [ADD/INPUT]   | 00000   | Wait until the codes become stabilized and press [ADD/INPUT]                                   |
| 6     | Press [HOLD/^] to change to the desired number for the standard weight, press [DIV.SHI/<] to shift digits | 03000   | 03000 is the standard weight of 3000kg to be loaded.   |
| 7     | After the standard weight is loaded, press [ADD/INPUT]  | 34683   | 34683 is the encode number of standard weight - 3000kg.  |
| 8     | Press [ADD/INPUT]   | 3000    | Calibration is completed. The scale is in weighing mode. The current weight load is displayed. |

- Note: 1. **Please make sure to wait until the encode is stabilized then press [ADD/INPUT]. Or it will lead incorrect weighing results.**
2. **Do not calibrate the scale without standard weight.**

## 8. Dimensioned Drawing of Scale

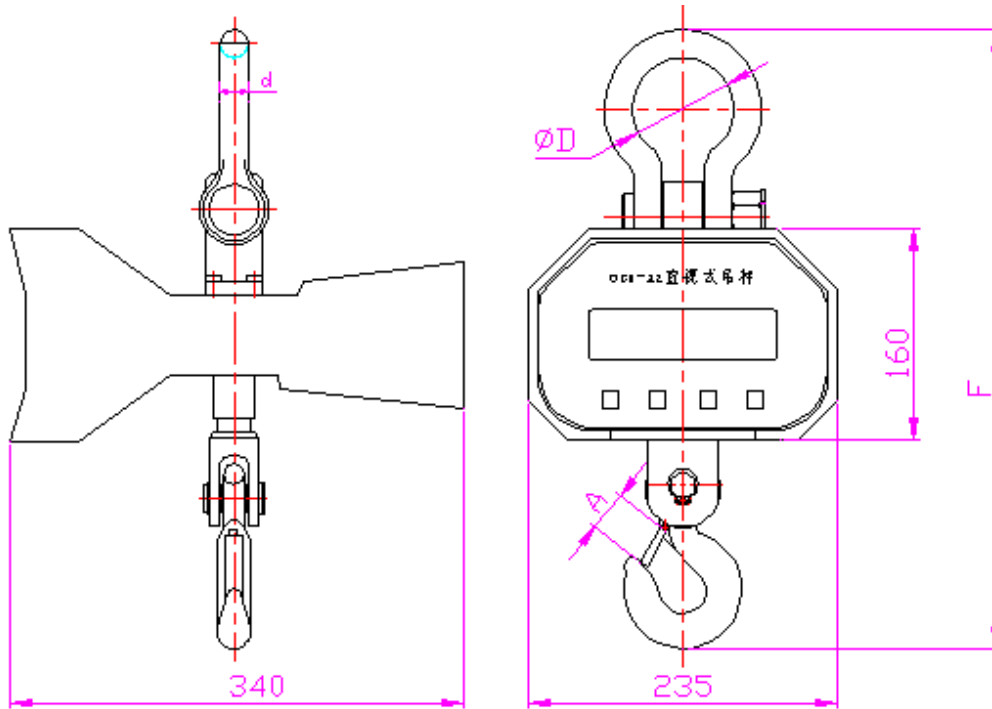

| Mode      | Maximum Capacity (ton) | d   | A  | D   | F   |
|-----------|------------------------|-----|----|-----|-----|
| OCS-XZ-06 | 0.6                    | Φ21 | 34 | Φ76 | 517 |
| OCS-XZ-1  | 1                      | Φ21 | 34 | Φ76 | 517 |
| OCS-XZ-2  | 2                      | Φ21 | 34 | Φ76 | 522 |
| OCS-XZ-3  | 3                      | Φ23 | 40 | Φ76 | 543 |
| OCS-XZ-5  | 5                      | Φ26 | 48 | Φ80 | 692 |
| OCS-XZ-10 | 10                     | Φ36 | 52 | Φ90 | 710 |

## 9. Instruction of Remote Controller

Remote Control & Usage



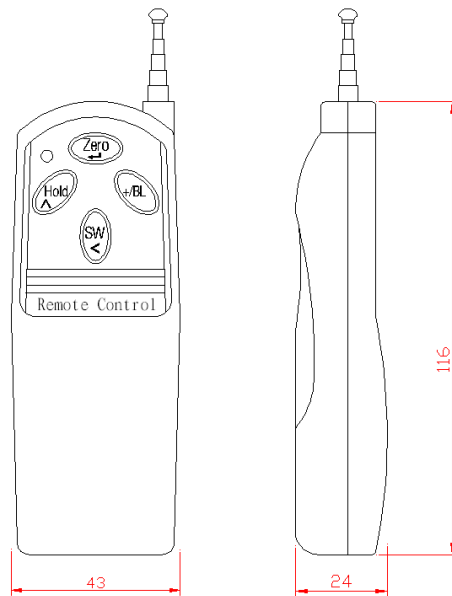

- i. SW: to perform division change as [DIV.SHI/<] key on the display panel.
- ii. Press Hold: – to Hold the settled values.
- iii. Press Zero: – to zero out the current displayed value as [ZERO] on the display panel.
- iv. Press BL:– to perform ADD/INPUT function as [ADD/INPUT] on the display panel.

★ The products are subject to change without notice.